

LUXOR WORKSPACES

www.luxorworkspaces.com
800-323-4656

LLMC10 Modular Charging Cabinet Assembly Instructions

Tools Required:
Phillips Head Screwdriver

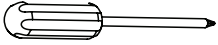

Parts Key

A x1

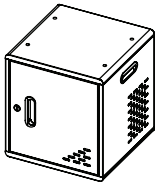

Charging Cabinet

B x1

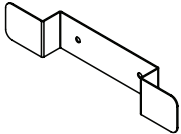

Cord Wrap

C x2

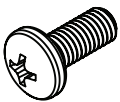

Bolt,
Phillips Head

D x4

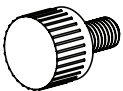

Thumbscrew

- 1** Position cord wrap on the rear of the cabinet, over the corresponding threaded mount holes.

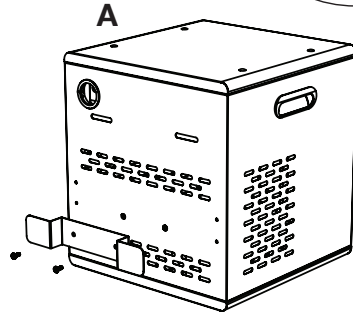
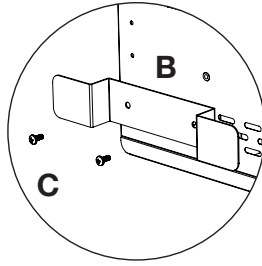

- 2** Insert each bolt into a lock washer, then a flat washer, then use to attach the casters to the Dolly.

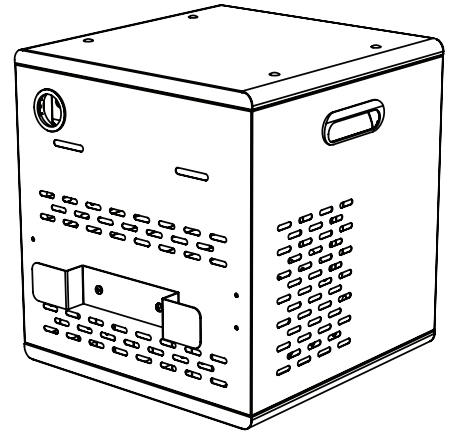

- 3** Remove the drawer from the bottom/lower cabinet by pressing the release lever on each side of the drawer track.

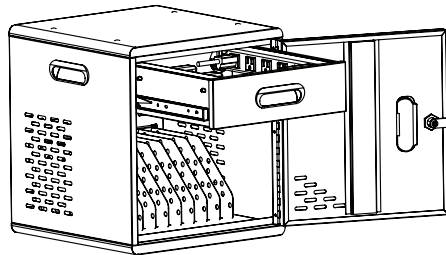
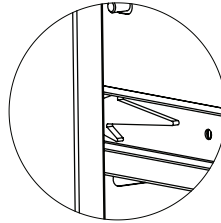

- 4** Remove the rubber caps from the top of the cabinet.

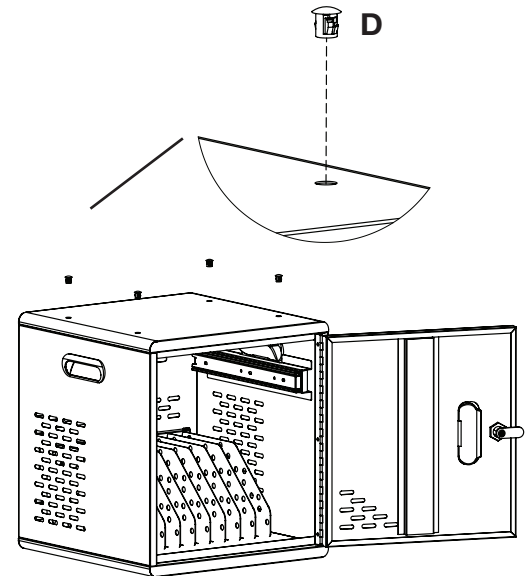

- 5** Position a second cabinet on top, aligning the threaded mount holes.

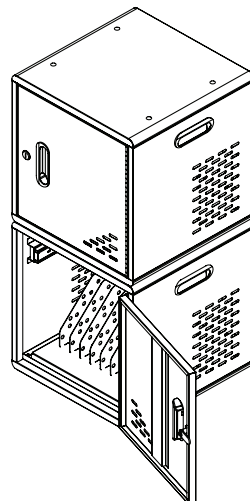

- 6** Using the thumbscrews attach the lower Cabinet to the upper Cabinet.

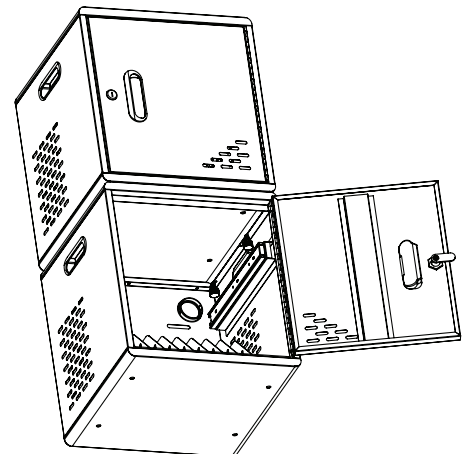

LLMCWP Modular Charging Cabinet – Wall Mount Bracket Assembly Instructions

Tools Required:
Phillips Head Screwdriver

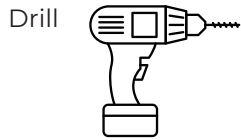
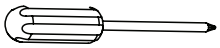

Parts Key

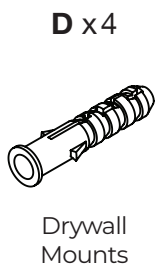
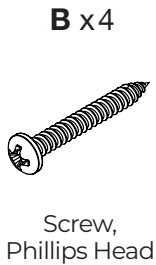
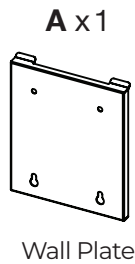

1 Hold mounting plate in desired position on the wall, mark the center of the four mounting holes.

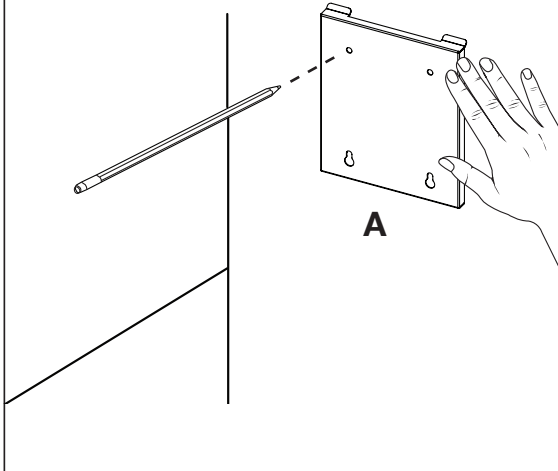

2 Pre drill holes in wall and insert drywall mounts.

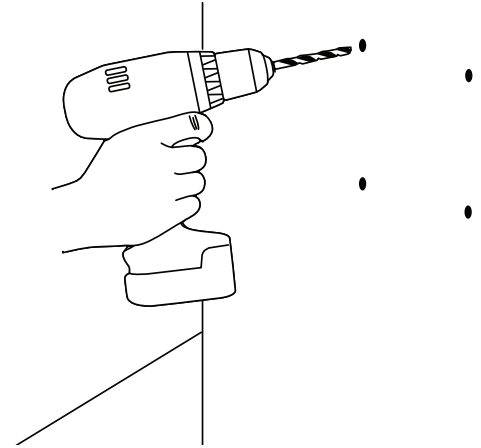

3 Once drywall mounts have been inserted, attach the mounting plate to the wall using four washers and four screws.

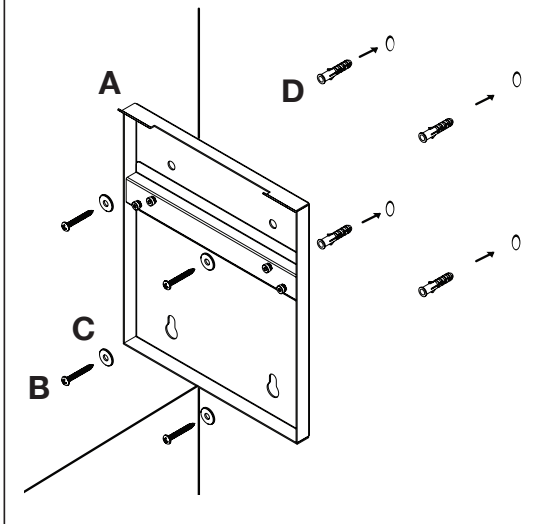

4 Tilt cabinet and hang onto mounting bracket.

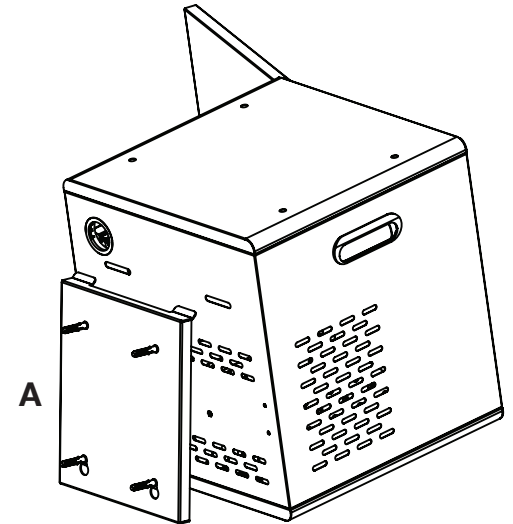

5 Secure cabinet to mounting bracket from the inside of the cabinet using four screws.

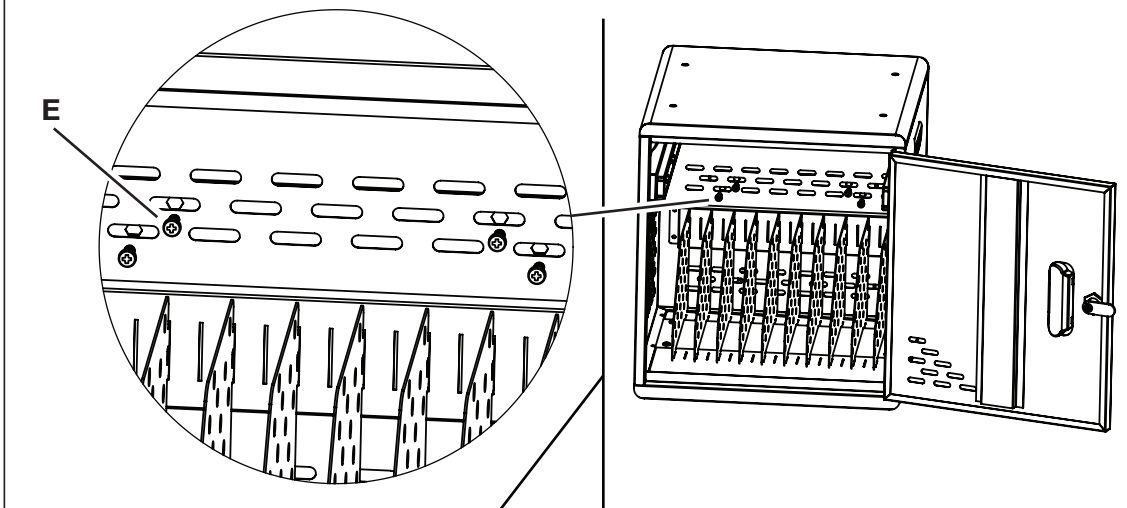

LUXOR

WORKSPACES

www.luxorworkspaces.com
800-323-4656

LLMCDP Modular Charging Cabinet - Double Dolly Assembly Instructions

Tools Required:

Phillips Head Screwdriver



Parts Key

A x2

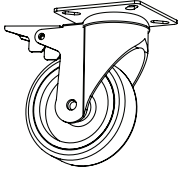

Caster,
Locking

B x2



Caster,
Non-Locking

C x16

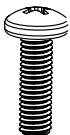

Bolt,
Phillips Head

D x16



Lock Washer

E x16



Flat
Washer

F x8



Thumbscrew

- 1 Flip the Dolly over and position the casters over the corresponding threaded mount holes.

IMPORTANT: Position the locking casters on the end next to the power strip.

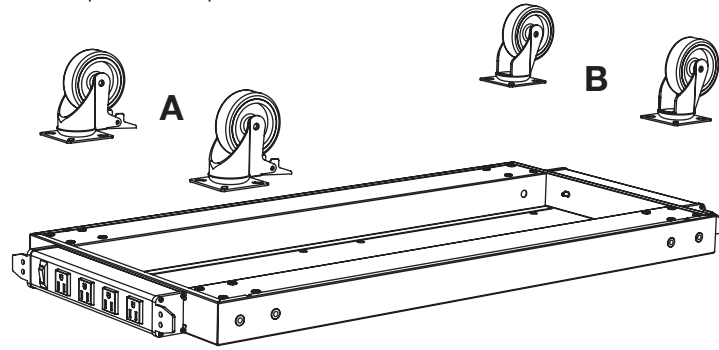

- 2 Insert each bolt into a lock washer, then a flat washer, then use to attach the casters to the Dolly.

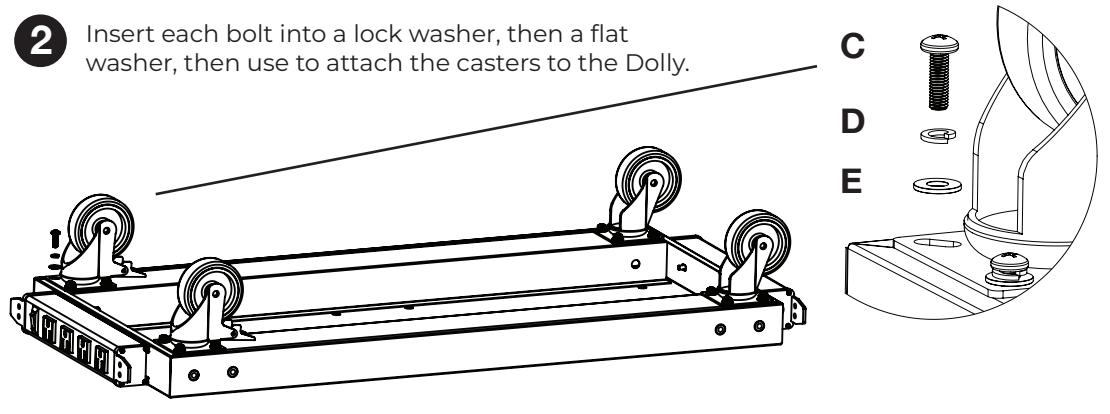

- 3 Using the thumbscrews, attach the Modular Charging Cabinets.

IMPORTANT: Position the Charging Cabinets so the cabinet doors face perpendicular to the edges of the Dolly with the power strips.

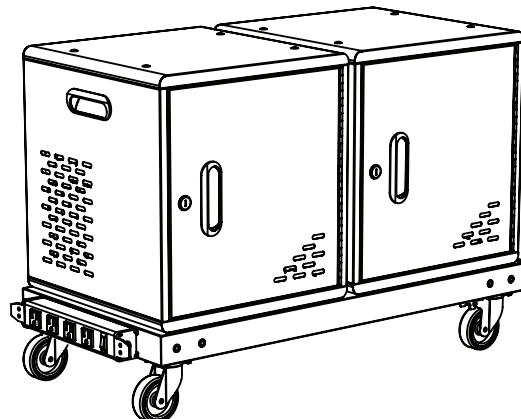
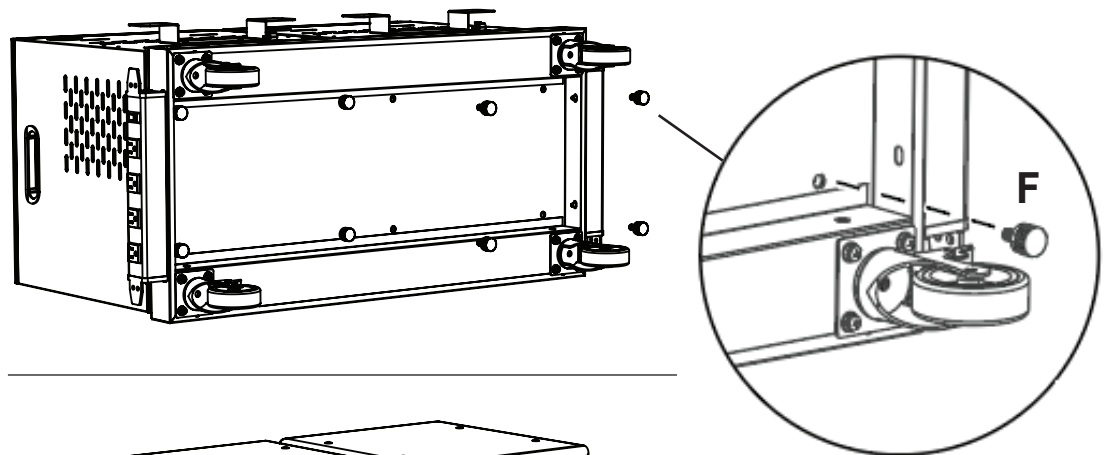

LLMCSP Modular Charging Cabinet - Single Dolly Assembly Instructions

Tools Required:
Phillips Head
Screwdriver



Parts Key

A x2

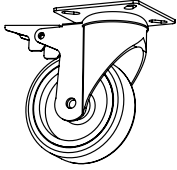

Caster, Locking

B x2



Caster, Non-Locking

C x16

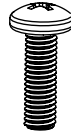

Bolt, Phillips Head

D x16



Lock Washer

E x16



Flat Washer

F x4

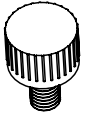

Thumbscrew

- 1** Flip the Dolly over and position the casters over the corresponding threaded mount holes.

IMPORTANT: Position the locking casters on the end next to the power strip.

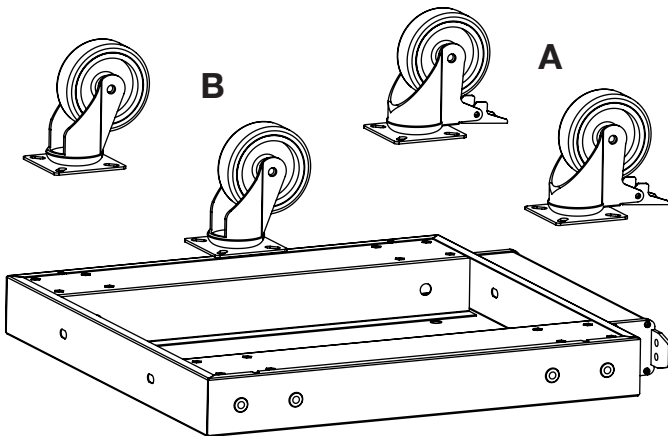

- 2** Insert each bolt into a lock washer, then a flat washer, then use to attach the casters to the Dolly.

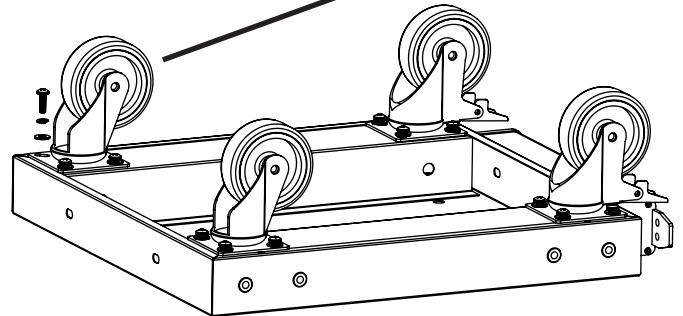
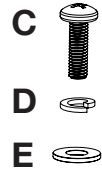

- 3** Using the thumbscrews, attach the Modular Charging Cabinet.

IMPORTANT: Position the Charging Cabinet so the cabinet door faces perpendicular to the edge of the Dolly with the power strip.

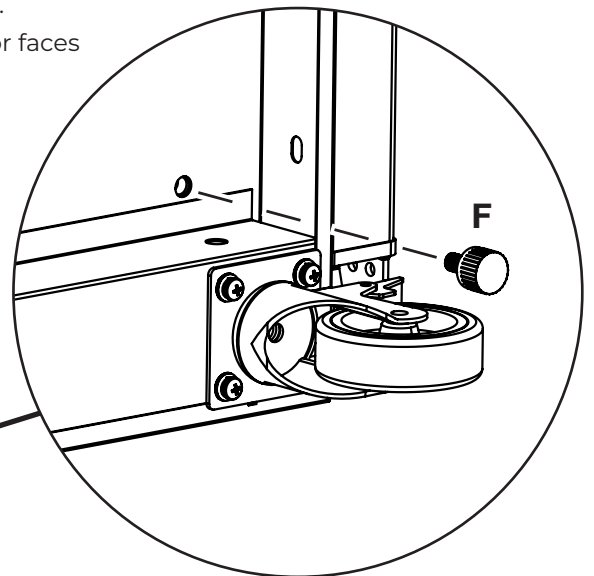
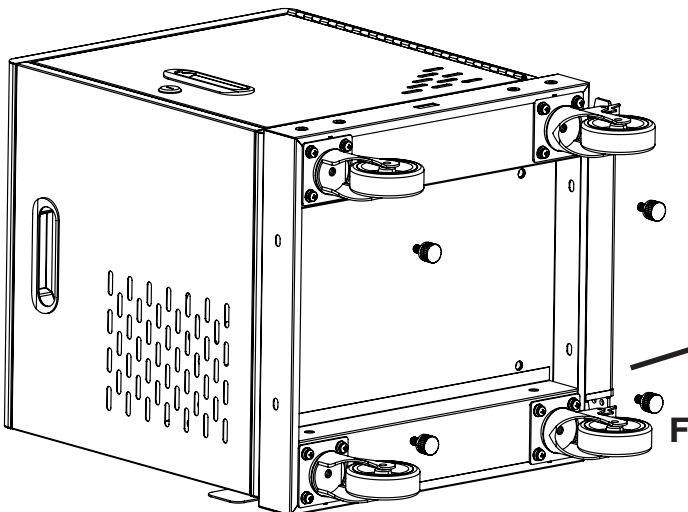

LLMCPH Modular Charging Cabinet – Dolly Handle Assembly Instructions

Parts Key

B x4

A x1

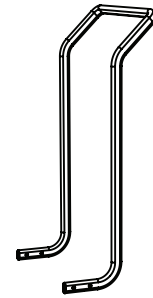

Handle



Bolt, Socket Head

C x4



Split Washer

- 1 Line the handle up with the corresponding threaded mount holes on the sides of the Dolly.
NOTE: While the handle can be attached to either end, it's generally best to attach the handle to the end with the power strip and caster locks.

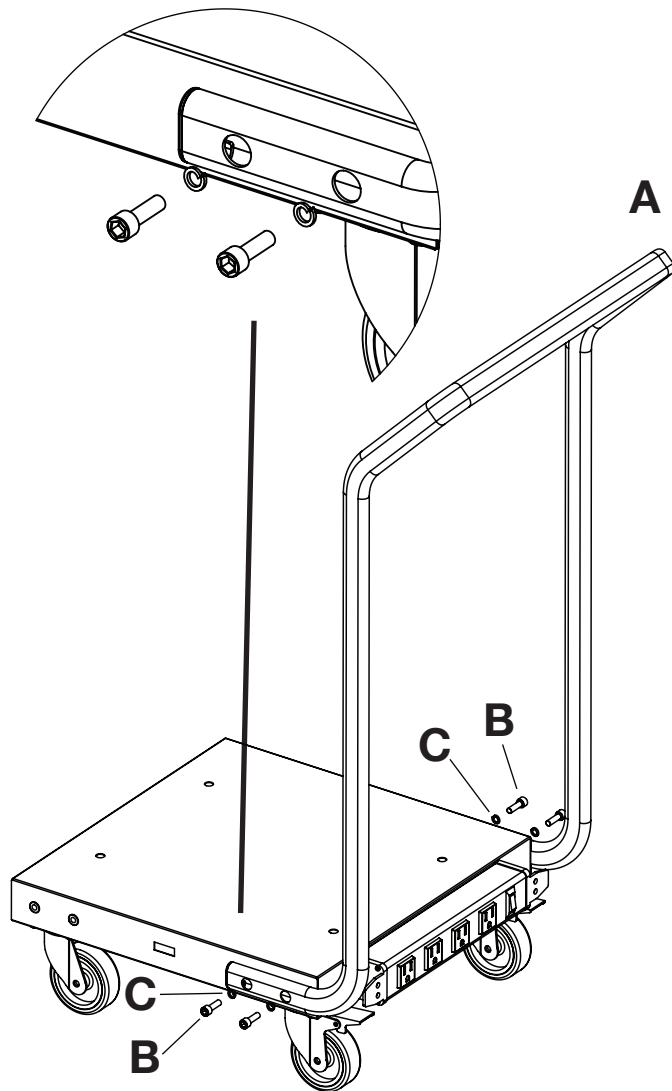

- 2 Use the socket head bolts and split washers to attach the handle to the Dolly.

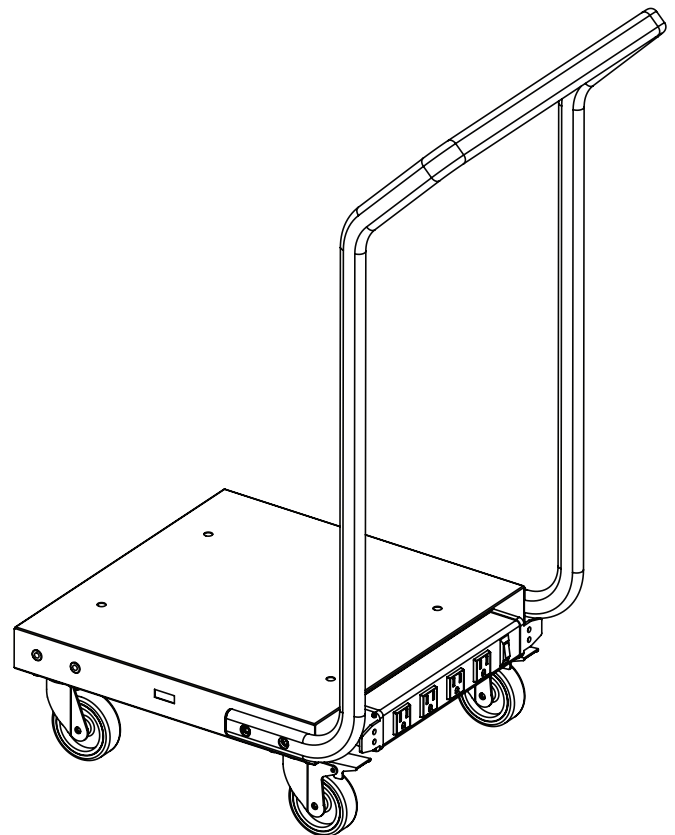

LUXOR WORKSPACES

www.luxorworkspaces.com
800-323-4656

LLMCDC Modular Charging Cabinet - Dolly Connection Plate Assembly Instructions

Tools Required:
Phillips Head Screwdriver

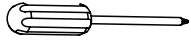

* Phillips head bolts come with the Dolly assemblies.
** Thumbscrews come with the Modular Charging Cabinet assemblies.

Parts Key A x 1

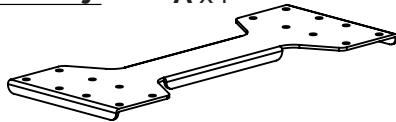

Connection Plate

B x 4

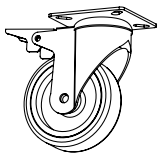

Caster,
Locking

C x 4



Caster,
Non-Locking

D x 32



Bolt,
Phillips Head

E x 32



Lock Washer

F x 32



Flat
Washer

G x 8



Thumbscrew

1

Flip the Dollies over, position them end-to-end with the power strips facing out, and position the casters at each corner over the corresponding threaded mount holes.

IMPORTANT: Position at least one set of locking casters on one end. If desired, you can place a locking caster at all four corners.

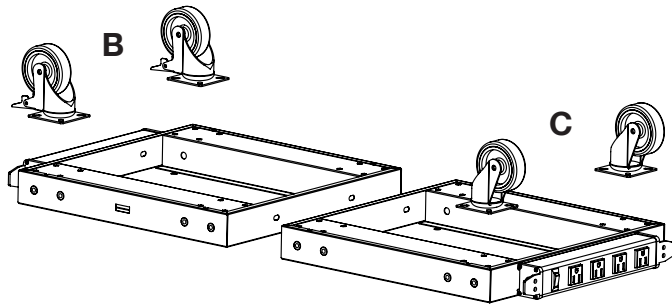

2

Position the Connection Plate over the corresponding threaded mount holes where the two Dollies are joined.

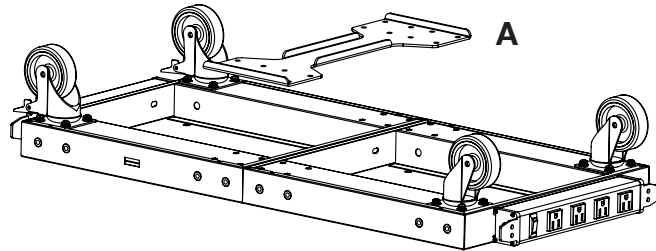

3

Insert each bolt into a lock washer, then a flat washer, then use 16 bolts to attach the casters to the Dollies.

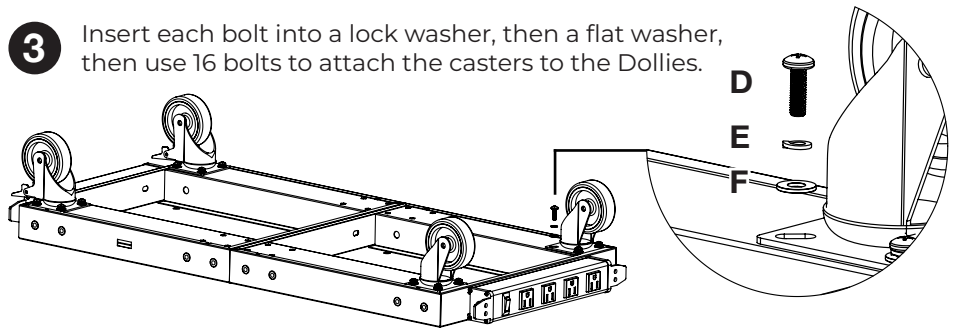

4

Use the remaining 16 bolts to attach Connection Plate to the Dollies.

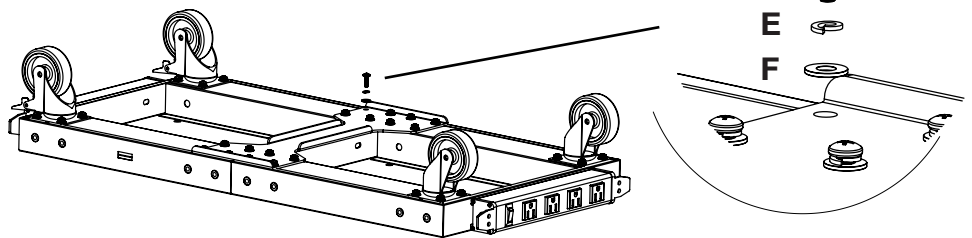

5

Using the thumbscrews, attach the Modular Charging Cabinets.

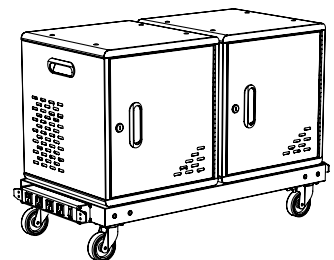
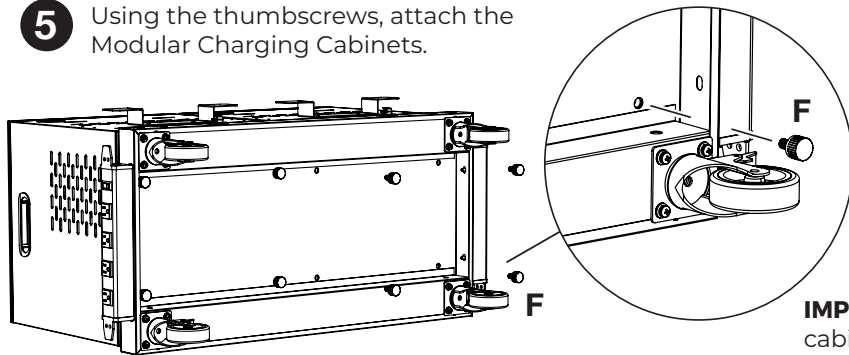

IMPORTANT: Position the Charging Cabinets so the cabinet doors face perpendicular to the power strips.